



GROUP
PLASTICS

PRODUCT CATALOG



DESCRIPTION

- Light protective goggles, single lens, with molded and integrated side protection, which can be used individually or over prescription glasses
- CE marking - EN166:2001
- Ideal for the Engineering, Construction, Industry, Carpentry and Laboratories sectors
- Clean with warm water, soap and a soft cloth or non-abrasive disinfectant solution
- Store in a clean, dry and dust-free place, preferably in a suitable purpose box
- Designed and produced in Portugal

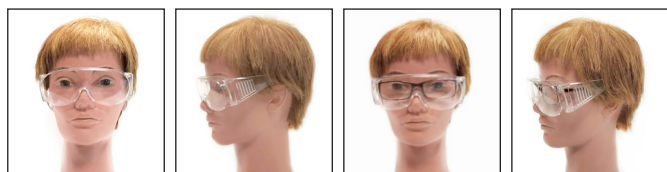

SINGLE COLOR
011.00167

DIMENSIONS

TECHNICAL FEATURES

Material	Polycarbonate
Length	156mm
Width	155mm
Distance Between Frames	156mm
Weight	40g
CE Conformity	EN166:2001
Optical class	1

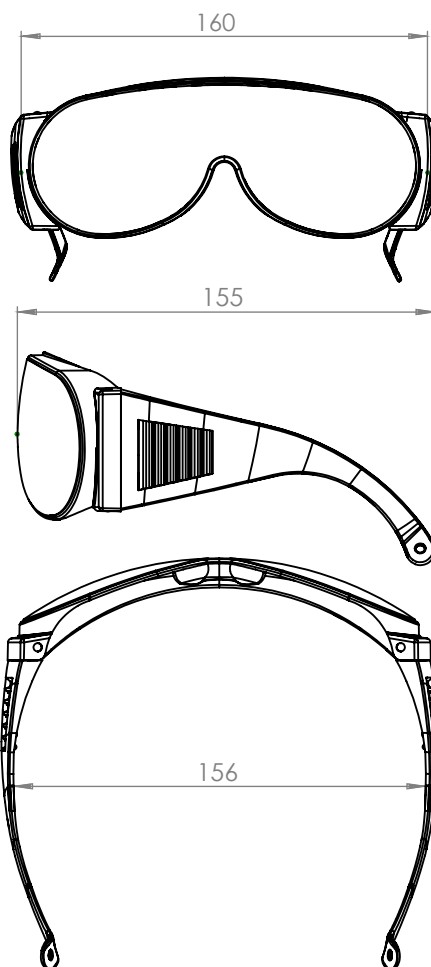

LOGISTIC DATA

Box	400x400x170mm
Quantity	50un
Packaging	Individual Plastic Bag



DESCRIPTION

- EN840 Certification
- Body and cover in high strength HDPE
- Resistant to UV, cold, heat, and chemicals
- Lid opens 270 degrees and is fixed by robust shaft
- Smooth surfaces for easy cleaning
- Integral handle with textured surface to increase the comfort and the easiness of transport
- Wheels in wood and plastic composite with robust rubber tires and galvanized steel shaft, for silent displacement
- Wheels Ø 200mm
- Completely recyclable at life end

EXTRA OPTIONS

- Foot Pedal
- Hot Stamping
- IML

LID STANDARD COLORS



BODY STANDARD COLORS



TECHNICAL FEATURES

Capacity	120 l
Length	550mm
Width	470mm
Width Between Axis	500mm
Height	900mm
Height Without Lid	860mm
Ø Wheels	200mm
Weight	6,8kg
Load	60kg

LOGISTIC DATA

Pallet 1200x1000x2600	44
90 cbm Truck 26 pallets	1144
20' DC 10 pallets	360
40' DC 21 pallets	756
40' HC 21 pallets	924

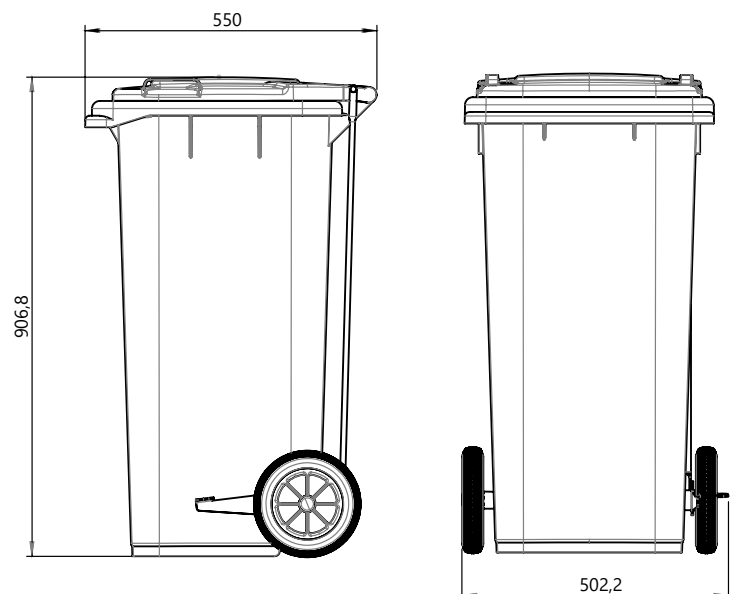









































PRODUCT REFERENCES

LID STANDARD COLORS



BODY STANDARD COLORS



Body	Lid	Product Reference Without Foot Pedal	Product Reference With Foot Pedal
		011.00601	011.00605
		011.00629	011.00634
		011.00630	011.00635
		011.00631	011.00636
		011.00632	011.00637
		011.00633	011.00638
		011.00618	011.00624
		011.00615	011.00623
		011.00617	011.00622
		011.00620	011.00645
		011.00619	011.00644
		011.00603	011.00607
		011.00625	011.00639
		011.00627	011.00640
		011.00616	011.00641
		011.00628	011.00642
		011.00602	011.00643
		011.00626	011.00606
		011.00612	011.00611
		011.00609	011.00610



DESCRIPTION

- Manufactured from HDPE using the injection moulding method and 100% virgin raw material
- Compatible with EN 840-1-5-6
- Smooth surface for easy cleaning
- Resistant to UV, cold, heat, and chemicals
- Lid opener 270 degree and fixed through two metal pins
- Print area on body and lid
- Ø 200 mm wheels, 2 with breaks
- Smooth-running wheels with breaks
- Designed to accommodate data carriers
- Compatible with standard lifting equipment

EXTRA OPTIONS

- Foot pedal
- Hot Stamping
- Screen Printing
- Lid in Lid
- Lock System

LID AND BODY AVAILABLE COLORS



LOGO APPLICATION AREAS

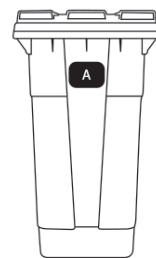

A: 250x250 mm

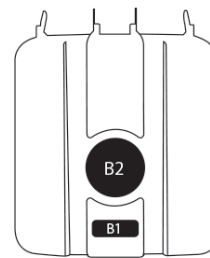

B1: 115x45 mm
B2: Ø 150 mm

TECHNICAL FEATURES

Capacity	240l
Length	600 mm
Base Length	400 mm
Width	750 mm
Width Between Wheels	400 mm
Height	1070 mm
Height Without Lid	1000 mm
Ø Wheels	200 mm
Weight	13 kg
Load	96 kg

LOGISTIC DATA

20' DC	280
40' DC	576
40' HC	670
90 cbm Truck	800



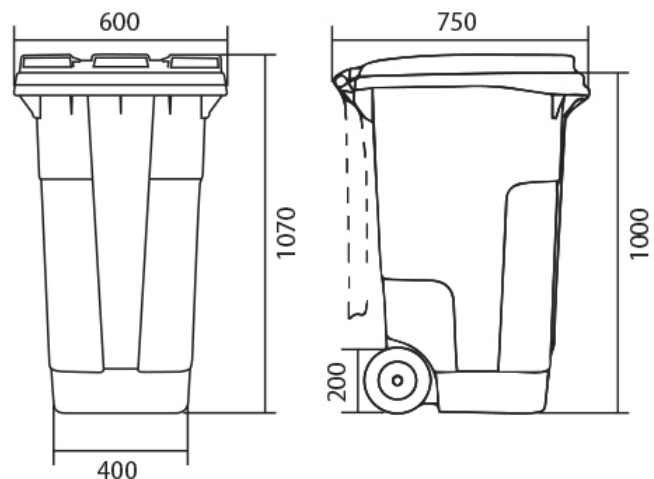





DIMENSIONS



PRODUCT REFERENCES

LID AND BODY AVAILABLE COLORS



Lid and Body Standard Colors	Product Reference Without Foot Pedal	Product Reference With Foot Pedal
	011.00123	011.00115
	011.00124	011.00116
	011.00125	011.00117
	011.00126	011.00118
	011.00127	011.00119
	011.00128	011.00120
	011.00129	011.00121
	011.00130	011.00122



DESCRIPTION

- Manufactured from HDPE using the injection moulding method and 100% virgin raw material
- Compatible with EN 840-2-5-6
- Smooth surface for easy cleaning
- Resistant to UV, cold, heat, and chemicals
- Lid opener 270 degree and fixed through two metal pins
- Print area on body and lid
- Ø 200 mm wheels, 2 with breaks
- Smooth-running wheels with breaks
- Designed to accommodate data carriers
- Compatible with standard lifting equipment

EXTRA OPTIONS

- Foot pedal
- Hot Stamping
- Screen Printing
- Lid in Lid
- Liquid Evacuation System

LID AND BODY AVAILABLE COLORS

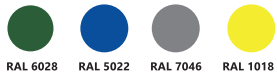

LOGO APPLICATION AREAS

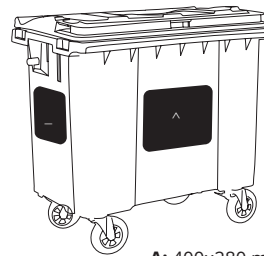

A: 400x280 mm
B: 300x280 mm

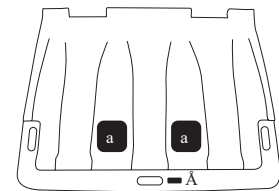

C: 55x25 mm
D: 180x50mm

TECHNICAL FEATURES

Capacity	1100l
Length	1380 mm
Lid Length	1193 mm
Base Length	1070 mm
Width	1060 mm
Width Between Axis	490 mm
Width Between Wheels	890mm
Height	1280 mm
Height Without Lid	1180 mm
Ø Wheels	200 mm
Weight	48,80 kg
Load	440 kg

DIMENSIONS

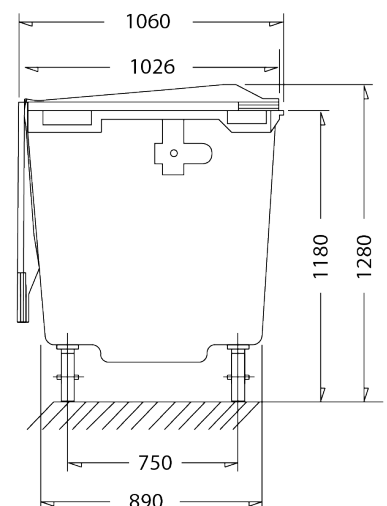
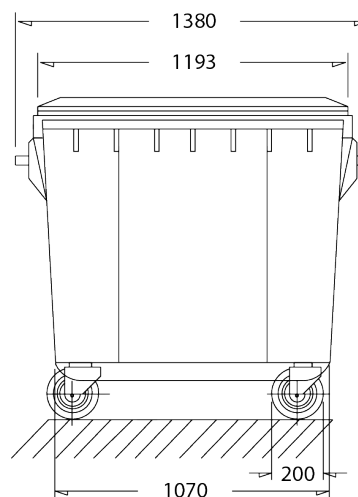







LOGISTIC DATA

20' DC	45
40' DC	90
40' HC	105
90 cbm Truck	156

PRODUCT REFERENCES

LID AND BODY AVAILABLE COLORS



Lid and Body Standard Colors	Product Reference Without Foot Pedal	Product Reference With Foot Pedal
	011.00109	011.00104
	011.00110	011.00105
	011.00111	011.00106
	011.00112	011.00107
	011.00113	011.00108
	011.00114	011.00103



DESCRIPTION

- Manufactured from HDPE using the injection moulding method and 100% virgin raw material
- Compatible with EN 840-2-5-6
- Smooth surface for easy cleaning
- Resistant to UV, cold, heat, and chemicals
- Lid opener 270 degree and fixed through two metal pins
- Print area on body and lid
- Ø 200 mm wheels, 2 with breaks
- Smooth-running wheels with breaks
- Designed to accommodate data carriers
- Compatible with standard lifting equipment

EXTRA OPTIONS

- Foot pedal
- Hot Stamping
- Screen Printing
- Lid in Lid
- Liquid Evacuation System

LID AND BODY AVAILABLE COLORS

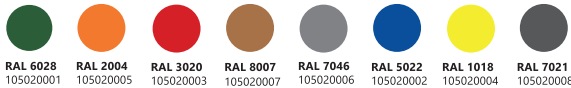

TECHNICAL FEATURES

Capacity	770l
Length	1380 mm
Lid Length	1223 mm
Base Length	1145 mm
Width	780 mm
Width Between Axis	490mm
Width Between Wheels	625 mm
Height	1270 mm
Height Without Lid	1170 mm
Ø Wheels	200 mm
Weight	41 kg
Load	310 kg

LOGISTIC DATA

20' DC	65
40' DC	135
40' HC	135
90 cbm Truck	180

LOGO APPLICATION AREAS

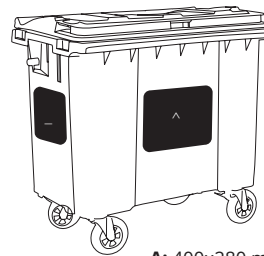

A: 400x280 mm
B: 300x280 mm

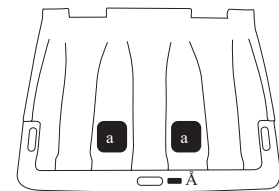

C: 55x25 mm
D: 210x50mm



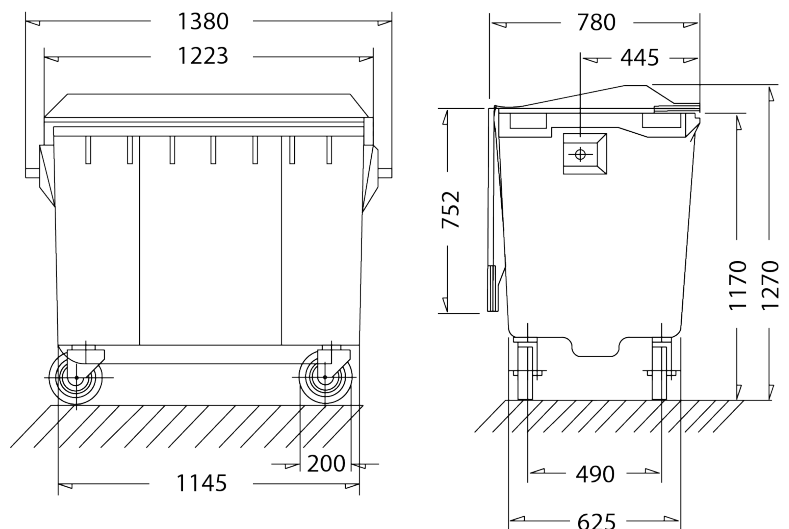



DIMENSIONS

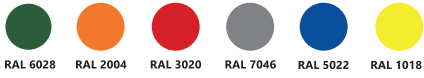

PRODUCT REFERENCES

LID AND BODY AVAILABLE COLORS



Lid and Body Standard Colors	Product Reference Without Foot Pedal	Product Reference With Foot Pedal
	011.00097	011.00091
	011.00098	011.00092
	011.00099	011.00093
	011.00100	011.00094
	011.00101	011.00095
	011.00102	011.00096



DESCRIPTION

- Manufactured from HDPE using the injection moulding method and 100% virgin raw material
- Compatible with EN 840-2-5-6
- Smooth surface for easy cleaning
- Resistant to UV, cold, heat, and chemicals
- Lid opener 270 degree and fixed through two metal pins
- Print area on body and lid
- Ø 200 mm wheels, 2 with breaks
- Smooth-running wheels with breaks
- Designed to accommodate data carriers
- Compatible with standard lifting equipment

EXTRA OPTIONS

- Foot pedal
- Hot Stamping
- Screen Printing
- Lid in Lid
- Liquid Evacuation System

LID AND BODY AVAILABLE COLORS

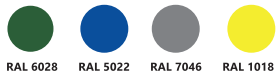

TECHNICAL FEATURES

Capacity	1100l
Length	1380 mm
Lid Length	1193 mm
Base Length	1070 mm
Width	1060 mm
Width Between Axis	490 mm
Width Between Wheels	890mm
Height	1280 mm
Height Without Lid	1180 mm
Ø Wheels	200 mm
Weight	48,80 kg
Load	440 kg

LOGISTIC DATA

20' DC	45
40' DC	90
40' HC	105
90 cbm Truck	156

LOGO APPLICATION AREAS

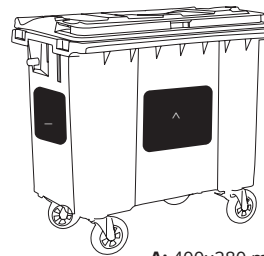

A: 400x280 mm
B: 300x280 mm

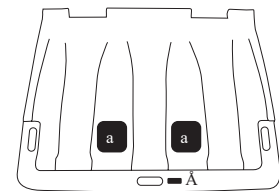

C: 55x25 mm
D: 180x50mm



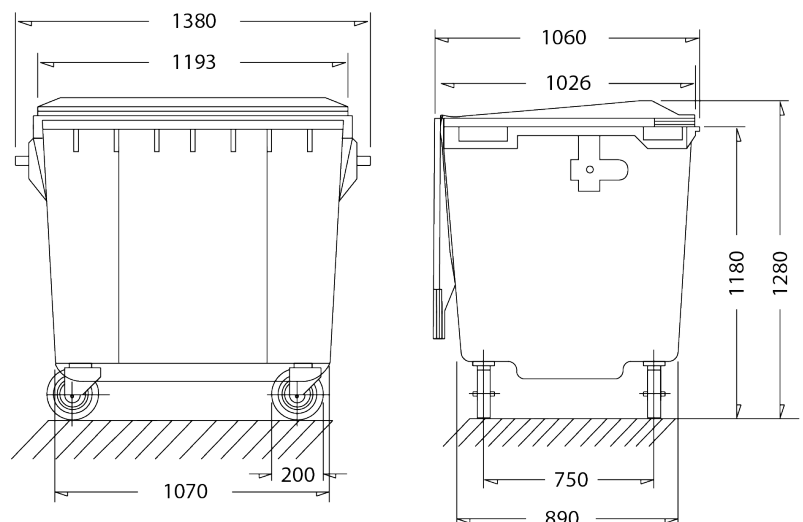

DIMENSIONS



PRODUCT REFERENCES

LID AND BODY AVAILABLE COLORS



Lid and Body Standard Colors	Product Reference Without Foot Pedal	Product Reference With Foot Pedal
	011.00087	011.00131
	011.00088	011.00084
	011.00089	011.00085
	011.00090	011.00086



DESCRIPTION

- Produced with 70% PLA + 30% PP
- Washable and easy to decontaminate
- Perforated box for multiple applications
- Stackable (121mm)
- Recyclable

EXTRA OPTIONS

- Other colors per customer specification

AVAILABLE COLORS



RAL 9005 RAL 9010 RAL 6028

011.00037 011.00158 011.00192

TECHNICAL FEATURES

Capacity	21,5l
Length	594mm
Width	394mm
Height	131mm
Stacking	10mm
Weight	1,37kg

DIMENSIONS

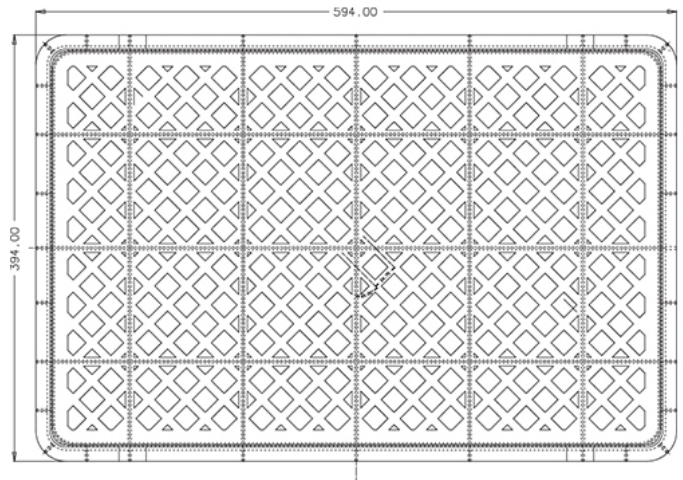

LOGISTIC DATA

Pallet 1200x800x2600	100
90 cbm Truck 33 pallets	3300
20' DC 11 pallets	935
40' DC 24 pallets	2040
40' HC 24 pallets	2280

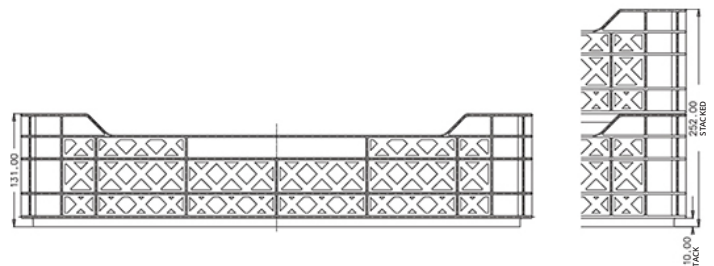

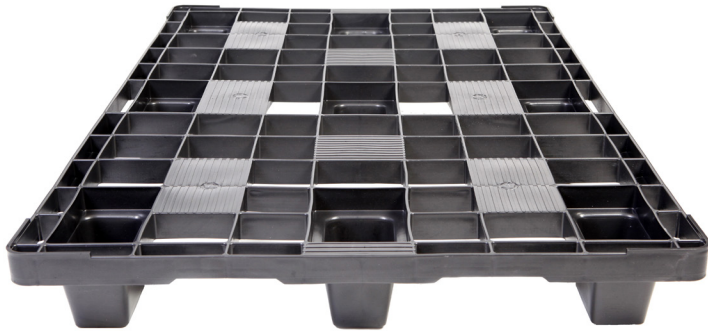

AVAILABLE COLORS



RAL 9005



RAL 9010

011.00034 011.00003

TECHNICAL FEATURES

Length	1200mm
Width	800mm
Height with corners	145mm
Height without corners	140mm
Stacking	45mm
Weight	5,25kg
Load	2000kg
Dinamic Load	750kg
Rack Load	300Kg

LOGISTIC DATA

90 cbm Truck 33 pallets	1650
20' DC 11 pallets	506
40' DC 24 pallets	1104
40' HC 24 pallets	1248

DESCRIPTION

- Produced in PP or HDPE
- Washable and easy to decontaminate
- Easiness with boxes loads
- Stackable (46mm)
- Returnable and Reusable
- Recyclable

EXTRA OPTIONS

- With or without corners
- With or without runners
- Other colors per customer specification

DIMENSIONS

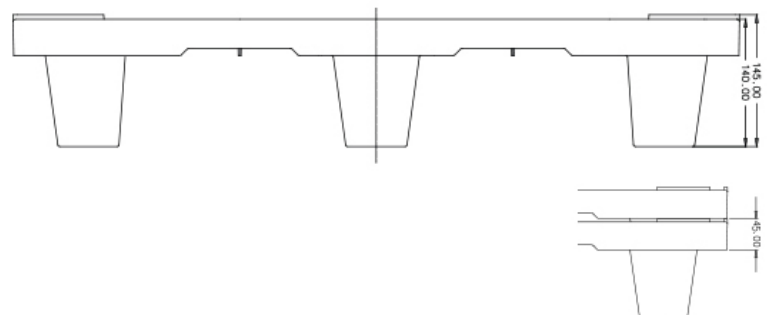
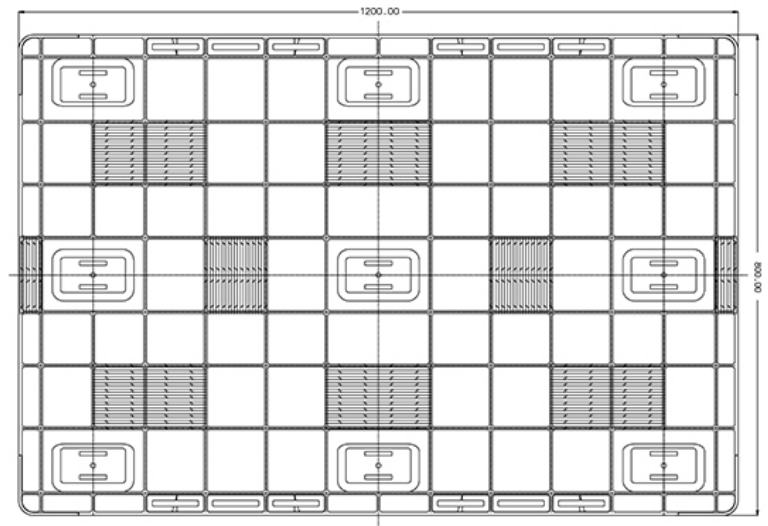

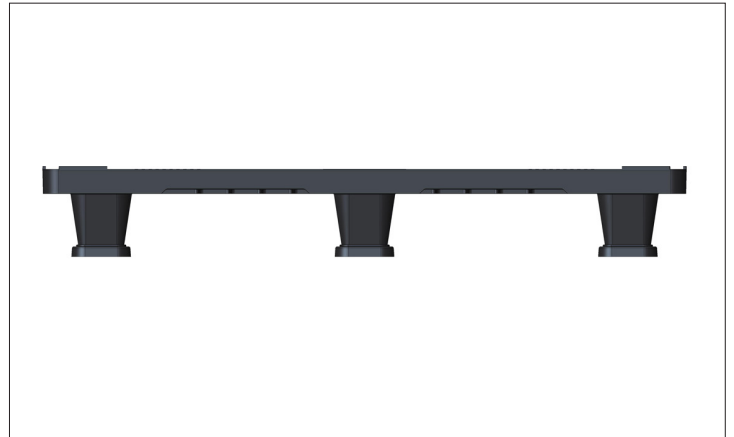
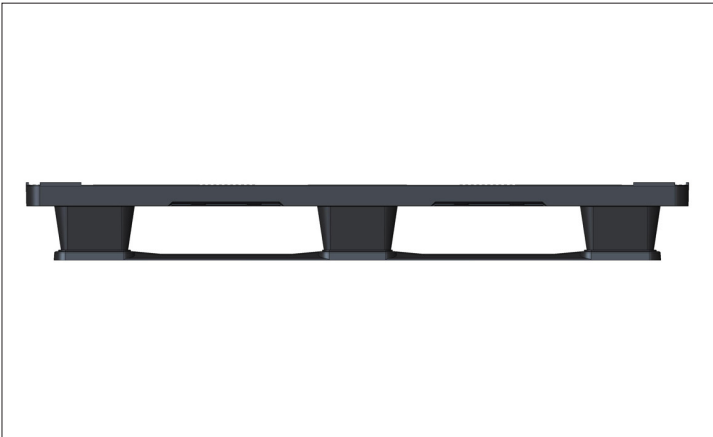
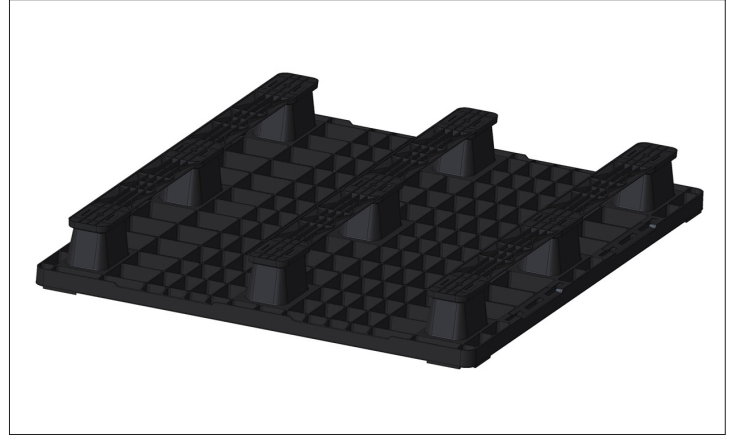

AVAILABLE COLORS



RAL 9005



RAL 9010

011.00034

011.00003



AVAILABLE COLORS



RAL 9005



RAL 9010

011.00160 011.00161

TECHNICAL FEATURES

Length	1200mm
Width	1000mm
Height with corners	145mm
Height without corners	140mm
Stacking	45mm
Weight	5,25kg
Load	2000kg
Dinamic Load	750kg
Rack Load	300Kg

LOGISTIC DATA

90 cbm Truck 26 pallets	1404
20' DC 10 pallets	470
40' DC 21 pallets	987
40' HC 21 pallets	1113

DESCRIPTION

- Produced in PP or HDPE
- Washable and easy to decontaminate
- Easiness with boxes loads
- Stackable (46mm)
- Returnable and Reusable
- Recyclable

EXTRA OPTIONS

- With or without corners
- With or without runners
- Other colors per customer specification

DIMENSIONS

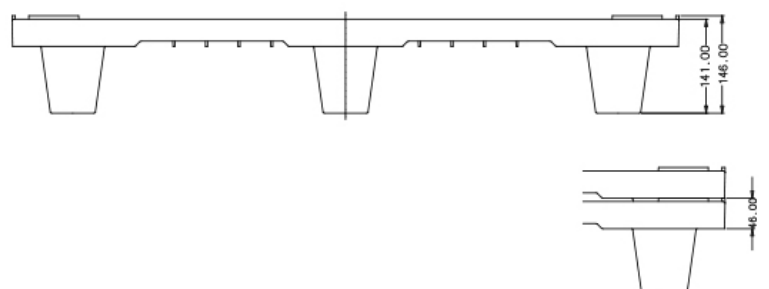
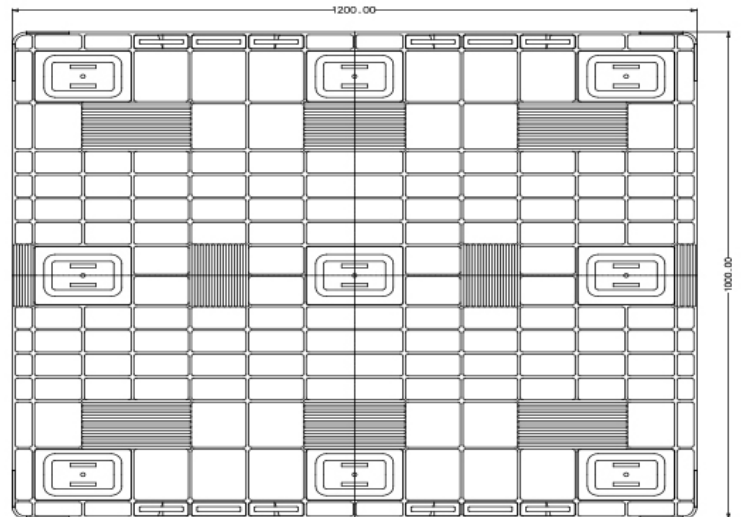

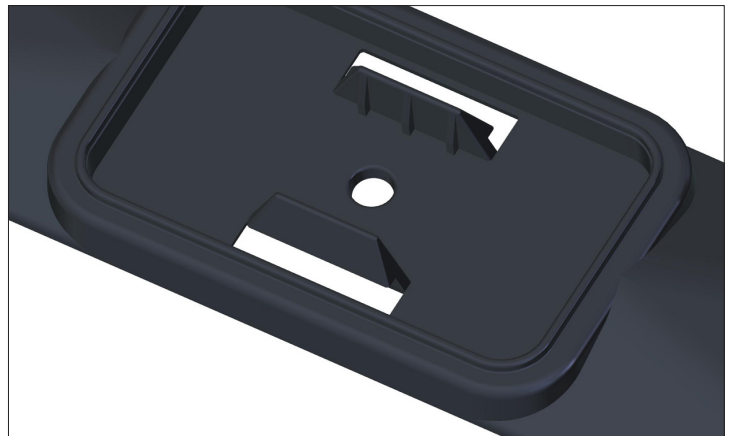
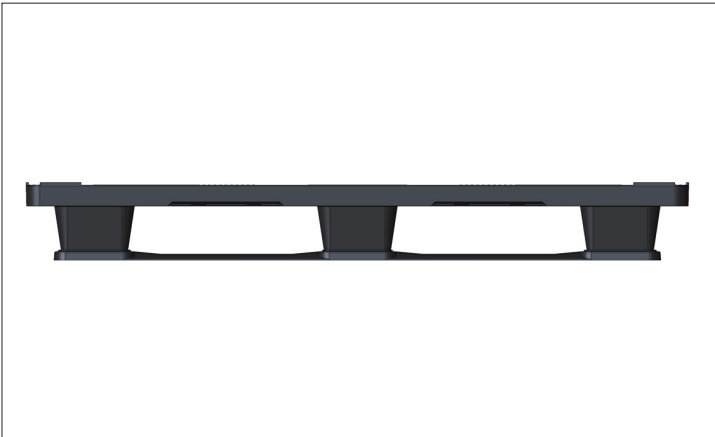
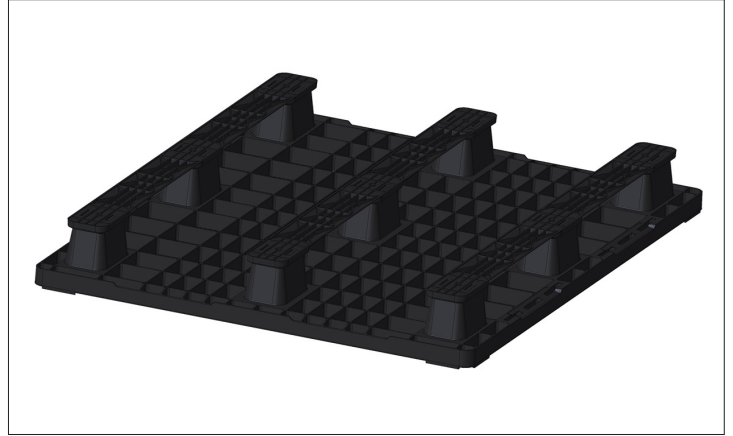

AVAILABLE COLORS



RAL 9005



RAL 9010

011.00160

011.00161

DESCRIPTION

- Produced in HDPE
- Washable and easy to decontaminate
- Stabilized with antioxidant and UV protection for atmospheric resistance
- Indoor or outdoor use
- Greater stability and resistance
- Suitable for transporting and packaging leaking products
- Non-Toxic
- Suitable for the food industry
- Totally recyclable

EXTRA OPTIONS

- 4 optional feet, 2 or 3 bars

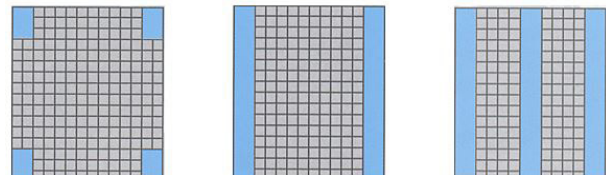

DIMENSIONS

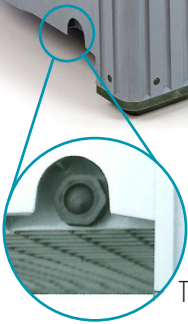
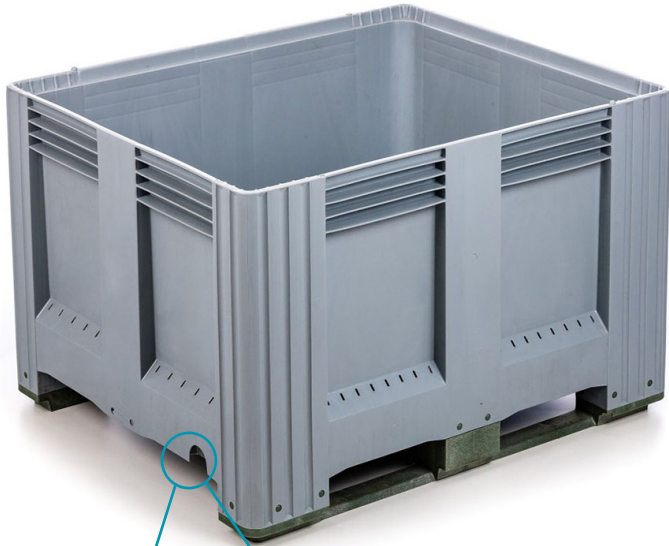
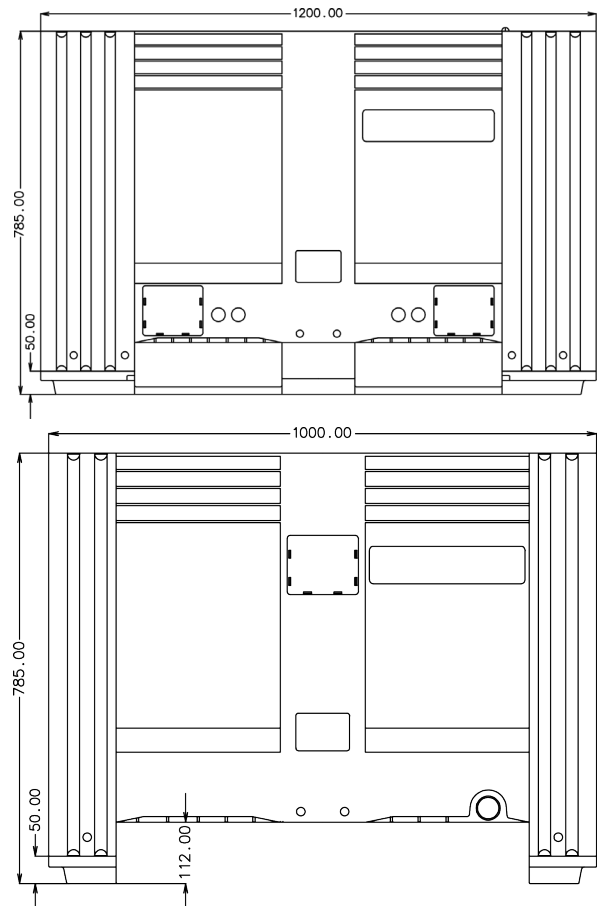

TAP PLACEMENT SYSTEM

SINGLE COLOR
011.00033

TECHNICAL FEATURES

Capacity	650l
Length	1200mm
Width	1000mm
Height	785mm
Height Handling with Bars	112mm
Bars Height	50mm
Weight with 2 Bars	41Kg
Load	650kg
Static Charge	2500kg
Stacking Capacity	4000kg

EXPORT DATA

90 cbm Truck	78
20' DC	20
40' DC	42
40' HC	63

DESCRIPTION

- Produced in HDPE
- Washable and easy to decontaminate
- Stabilized with antioxidant and UV protection for atmospheric resistance
- Indoor or outdoor use
- Greater stability and resistance
- Suitable for transporting and packaging leaking products
- Non-Toxic
- Suitable for the food industry
- Totally recyclable

EXTRA OPTIONS

- 4 optional feet, 2 or 3 bars

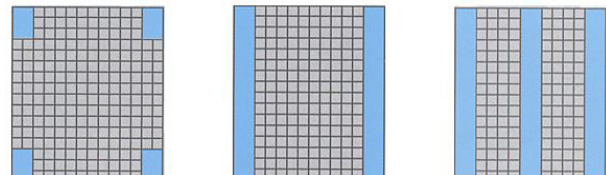

DIMENSIONS

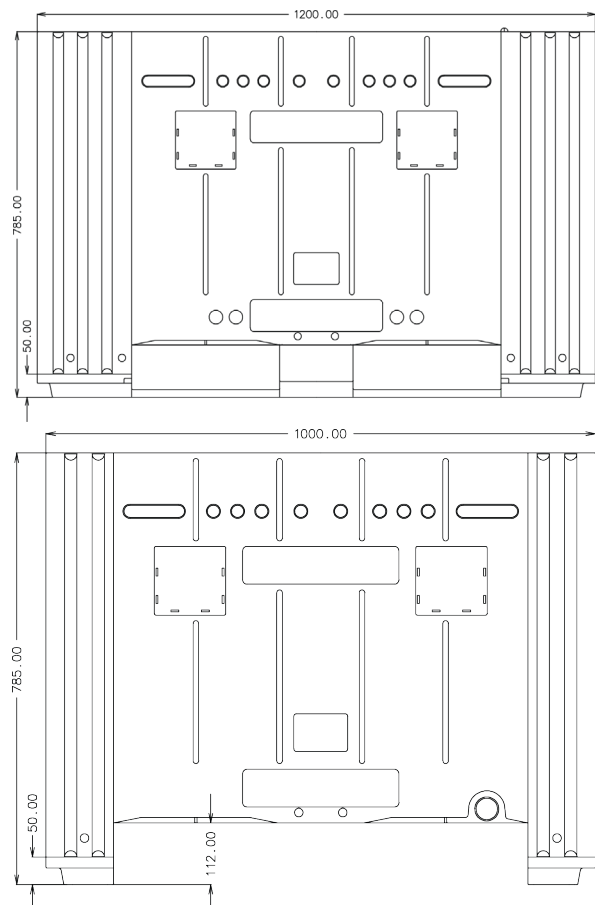

TAP PLACEMENT SYSTEM

SINGLE COLOR
011.00036

TECHNICAL FEATURES

Capacity	650l
Length	1200mm
Width	1000mm
Height	785mm
Height Handling with Bars	112mm
Bars Height	50mm
Weight with 2 Bars	45kg
Load	650kg
Static Charge	2500kg
Stacking Capacity	4000kg

EXPORT DATA

90 cbm Truck	78
20' DC	20
40' DC	42
40' HC	63

DESCRIPTION

- Produced in HDPE
- Washable and easy to decontaminate
- Stabilized with antioxidant and UV protection for atmospheric resistance
- Indoor or outdoor use
- Greater stability and resistance
- Suitable for transporting and packaging leaking products
- Non-Toxic
- Suitable for the food industry
- Totally recyclable

EXTRA OPTIONS

- 4 optional feet, 2 or 3 bars

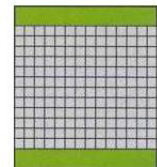
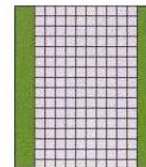
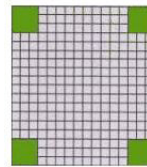
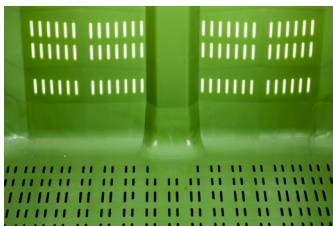

DIMENSIONS

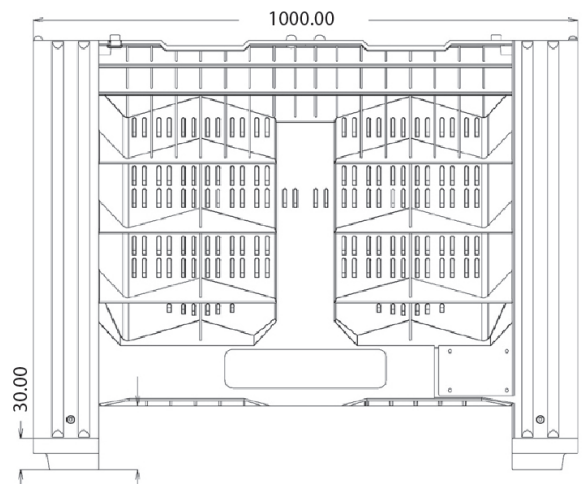
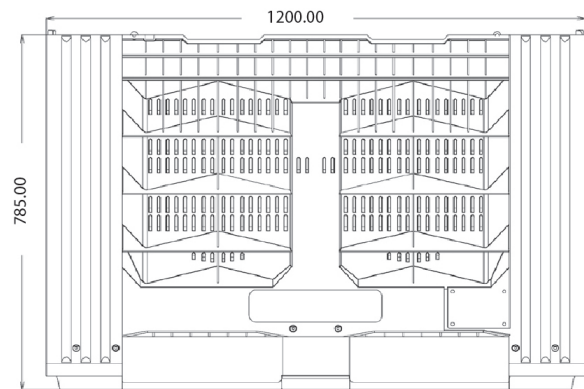

SINGLE COLOR
011.00039

TECHNICAL FEATURES

Capacity	690l
Length	1200mm
Width	1000mm
Height	785mm
Height Handling with Bars	110mm
Bars Height	30mm
Weight with 2 Bars	39Kg
Load	500kg
Static Charge	2000kg
Stacking Capacity	5000kg

EXPORT DATA

90 cbm Truck	78
20' DC	20
40' DC	42
40' HC	63



DESCRIPTION

- Produced in PP
- Stable and robust for long life
- Indoor or outdoor usage
- Stackable (50mm)
- Recyclable

EXTRA OPTIONS

- Other colors per customer specification

AVAILABLE COLORS

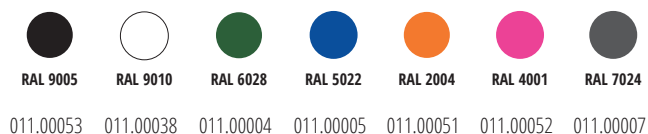

DIMENSIONS

TECHNICAL FEATURES

Length	361 mm
Width	417 mm
Height	462 mm
Stacking	50 mm
Weight	0,99 kg
Maximum load	120 kg

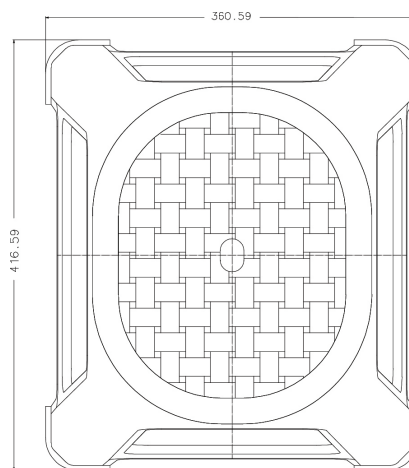

LOGISTIC DATA

Pallet 1200x800x2600	270
90 cbm Truck 33 pallets	8910
20' DC 11 pallets	3366
40' DC 24 pallets	7344
40' HC 24 pallets	8640

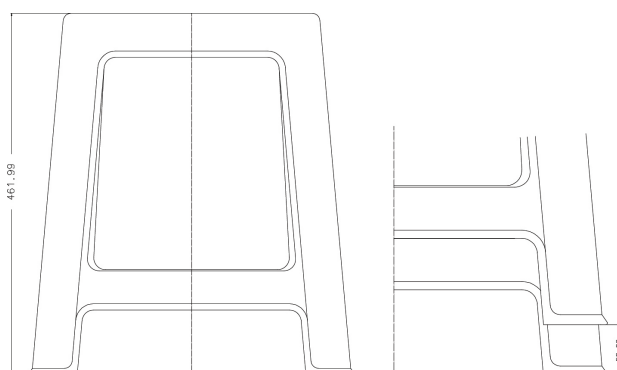

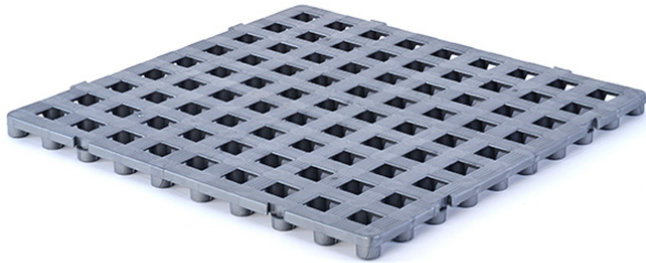

DESCRIPTION

- Produced in Low Density Polyethylene
- Non-slip surface
- Drainage capacity
- Washable and easy to decontaminate
- Indoor or outdoor use
- Suitable for food contact
- Resistant to acids, oils and solvents
- Compressive strength of 30 000Kg/m²
- Recyclable

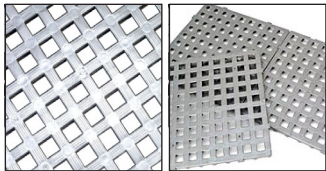

AVAILABLE COLORS



RAL 7024

011.00198

EXTRA OPTIONS

- Other colors per customer specification

DIMENSIONS

TECHNICAL FEATURES

Length	500mm
Width	500mm
Height	23,5mm
Weight	0,8kg
Compressive Strength	30 000 kg/m ²

LOGISTIC DATA

Pallet 1200x800x2600	560
90 cbm Truck 33 pallets	18480
20' DC 11 pallets	6160
40' DC 24 pallets	13440
40' HC 24 pallets	14256

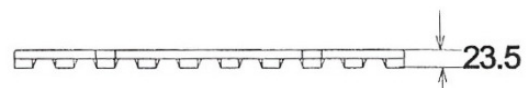
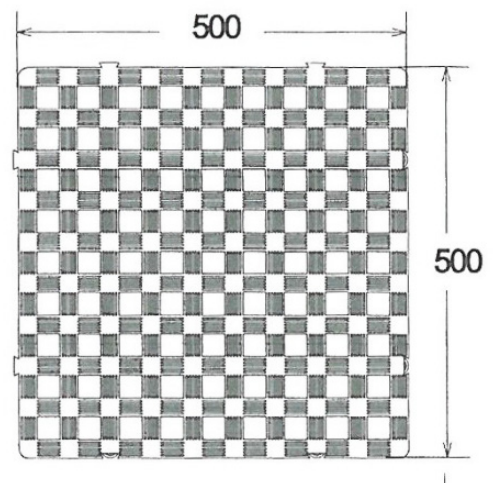



GROUP PLASTICS



Macro Group Plastics - Rua da Atalaia do Calvário, 415 3720-502 Oliveira de Azeméis - Portugal

Tel: +351 256 600 880

Fax: +351 256 600 889

store.macrogroupp.eu

email: plastics@macrogroupp.eu